



## Matrox Millennium P650 LVDS

### LVDS introduction

LVDS stands for Low Voltage Differential Signaling. It is a way to communicate data using a very low voltage swing differentially over two PCB traces or a balanced cable, creating low noise and providing low power consumption across frequency.

### Features

Part-Number	A-P65P64DS0004		
Graphics chip	Matrox Parhelia LX		
Dualhead-HF	Yes		
LVDS Transmitter frequency (primary and secondary)	165 MHz		
Memory	64 MB		
Memory type	DDR (Double Data Rate) SDRAM		
Card type	PCI (32-bit, 66MHz)		
Form Factor	Low-profile		
Connectors	2xLVDS		
OS Support	Please contact <a href="mailto:apps_eng@matrox.com">apps_eng@matrox.com</a>		
List Price	\$279.00 (USD)		
Power Consumption	3.3V	5V	12V
	0 W	17.5 W	4.6 W

### Environmental specifications

- Minimum/maximum ambient operating temperatures: 0 to 55 °C
- Minimum/maximum storage temperature: -40 to 75 °C
- Maximum altitude for operation: 3,000 meters
- Maximum altitude for transport: 12,000 meters
- Operating humidity: 20 to 80% relative humidity (non-condensing)
- Storage humidity: 5 to 95% relative humidity (non-condensing)



## Matrox Millennium P650 LVDS

### Maximum card dimensions

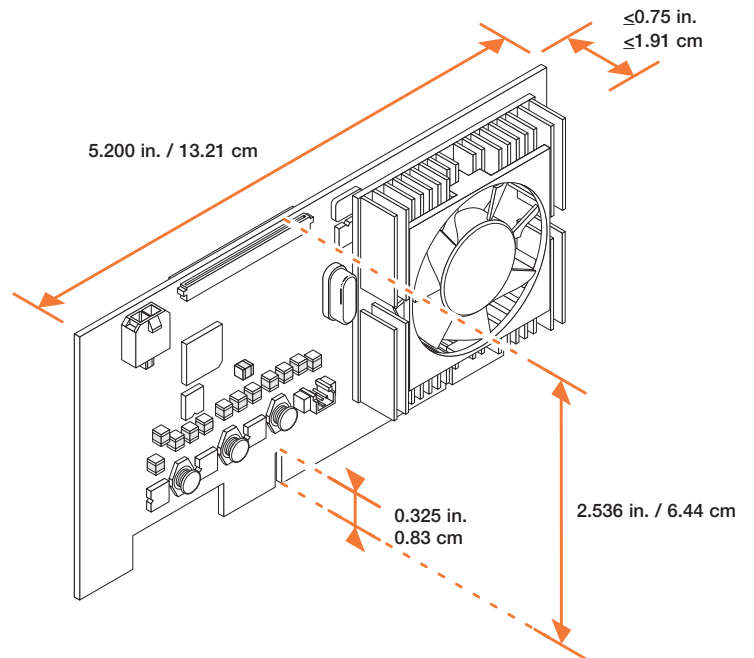
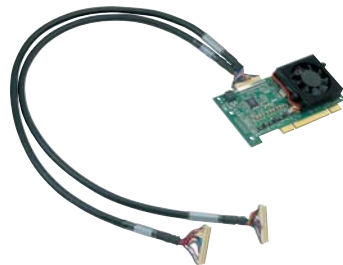

### Maximum resolution

Each head of the board can drive up to 1600x1200 at 60 Hz in 32 bits.

### LVDS cable design

- Each LVDS panel manufacturer uses a custom pinout for their LVDS connector. Therefore a custom LVDS cable needs to be designed specifically for each panel.
- The reference design and prototype creation of the cable can be supported by Matrox, provided the reception of the complete datasheet.
- The production cables are to be supported by the customer.

Please contact [apps\\_eng@matrox.com](mailto:apps_eng@matrox.com) for additional information